

Small traction motive power

NexSys®

POWER WHEN YOU NEED IT

NexSys® Bloc and Charger System

Designed to change the way you work





Faster, more flexible recharging puts you in charge

Designed for use with NexSys[®] blocs, NexSys bloc chargers slash recharge times and allow for flexible opportunity charging while optimizing bloc cycle life.



Robust Intercell Connections

To resist vibration and eliminate internal sparking, cell connectors are casted to the plates and bonded.

Pure Lead Plates

To provide more power, the plates in our NexSys[®] blocs are constructed from 99% pure lead. The plates are extremely thin, so more of them can fit into the bloc. More lead plates means more power.

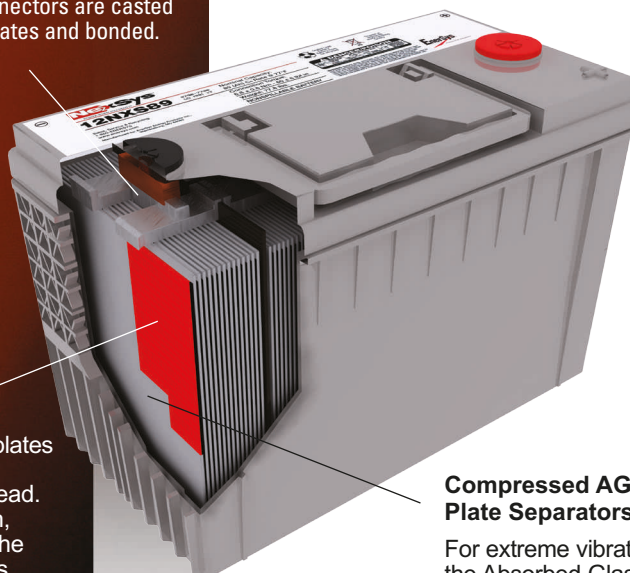

- AGM design holds acid in place to prevent spills, even when installed on its side

- Up to two year shelf life at 20°C

Compressed AGM Plate Separators

For extreme vibration resistance, the Absorbed Glass Mat (AGM) plate separators are compressed before being inserted into the case.

NexSys[®]

The bloc and charger system that will change the way you work

NexSys[®] blocs provide exceptional flexibility. Use them whenever you want and recharge them whenever you can – during breaks, or at the end of the shift. NexSys blocs can even be put back into service before they are fully charged.

Combining advanced bloc design technology with robust materials and construction, NexSys blocs also provide exceptional performance. Maintenance-free and highly resistant to shock and vibration, NexSys blocs will literally change the way you work.

Small traction applications include:

- Floor care/cleaning machines
- Pallet trucks
- Shuttle personnel carriers
- Industrial utility vehicles
- Automated Guided Vehicles (AGV)
- And many more...

Benefits that conventional blocs can't match

Virtually maintenance - free, NexSys® blocs feature a superior quality AGM separator with high electrolyte absorption and stability to enhance cyclic capability. Positive and negative plates are low impedance, high corrosion resistant thin plate grids manufactured from pure lead in a unique process.

The result? NexSys blocs offer optimized cycling performance and rapid recharging that conventional lead acid batteries – gel or flooded – simply cannot. When used with an EnerSys® approved charger, NexSys blocs offer a wide range of benefits:

- High energy throughput – up to 160% of C₅ or C₆ per 24 hours with an opportunity charging regime
- Long maintenance-free life cycle – up to 1,200 cycles at 60% DOD
- Extreme shock and vibration resistance
- Eco - friendly performance
- Minimum gassing: ideal for use in shops, public areas and sensitive manufacturing areas
- High recyclability
- Ideal for multi-shift operations
- Optimum machine availability
- Short recharge times – less than 3 hours at 60% DOD (with NexSys bloc charger)
- Suitable for opportunity charging
- Long shelf life (up to two years at 20°C)
- Easy installation
- More power in less space – NexSys blocs typically occupy 30% less space than the equivalent lead calcium ones.

Technical Data

NexSys® Battery	Voltage (V)	Nominal Capacity C ₅ [Ah] 1.7VPC @ 30°C	Nominal Capacity C ₂₀ [Ah] 1.7VPC @ 30°C	Dimensions (mm)				Weight (kg)	Standard Terminals	Terminal Adapter Options	Terminal Layout
				L	W	H	Term H				
12NXS26	12	26	30	250	97	147	144	9.6	M6 Female	A	1
12NXS36	12	36	42	250	97	197	194	13.2	M6 Female	A	1
12NXS38	12	38	42	197	165	170	162	17.4	M6 Female	A	1
12NXS61	12	61	63	280	97	264	248	19.1	M8 Female	-	2
12NXS85	12	85	97	395	105	264	248	27.2	M8 Female	-	2
12NXS86	12	86	100	330	172	214	219	35.1	3/8 -16" Female	A	1
12NXS90	12	90	104	302	175	223	227	31.5	M6 Female	A	3
12NXS120	12	120	128	338	173	272	273	43.0	M6 Female	A	3
12NXS137	12	137	154	455	172	238	238	47.6	M6 Female	B	2
12NXS157	12	157	183	455	172	273	274	53.1	M6 Female	B	2
12NXS158	12	158	187	561	125	283	263	51.2	M8 Female	B	2
12NXS177	12	177	210	561	125	317	297	59.4	M8 Female	B	2



Option A: SAE post



Option B: M6 male front terminal adapter



Terminal layout 1



Terminal layout 2



Terminal layout 3

Selecting the correct bloc, terminals and connection method

Determine your space restrictions

The first step is to access your bloc compartment. The amount and shape of space available may influence which bloc model and how many of them, can be used to fulfill your power needs. In many cases you may have several options to choose from. The difference being the amount of energy a bloc provides, and how many batteries can be fitted in your available space. The best choice will depend on which bloc or combination of blocs best fits your needs.

Note: Keep in mind that there must be sufficient space between blocs to allow for minor battery expansion during use. This assures proper airflow to keep bloc temperature down in hot environments.

Determine your power needs

The next step is to determine the total voltage of your current system and whether or not this amount of energy was adequate or if more power is needed. If the bloc being replaced provided sufficient power, a replacement bloc with similar capacity can be used. If your current bloc or blocs did not always meet your needs, a replacement bloc with higher capacity (or multiple blocs with collectively more capacity) should be used.

Determine which bloc or combination of batteries is best

Next decide which battery and how many will best meet your power requirements based on your system's required voltage. The best choice may be influenced by the size of your bloc compartment, your performance requirements, and cost considerations.

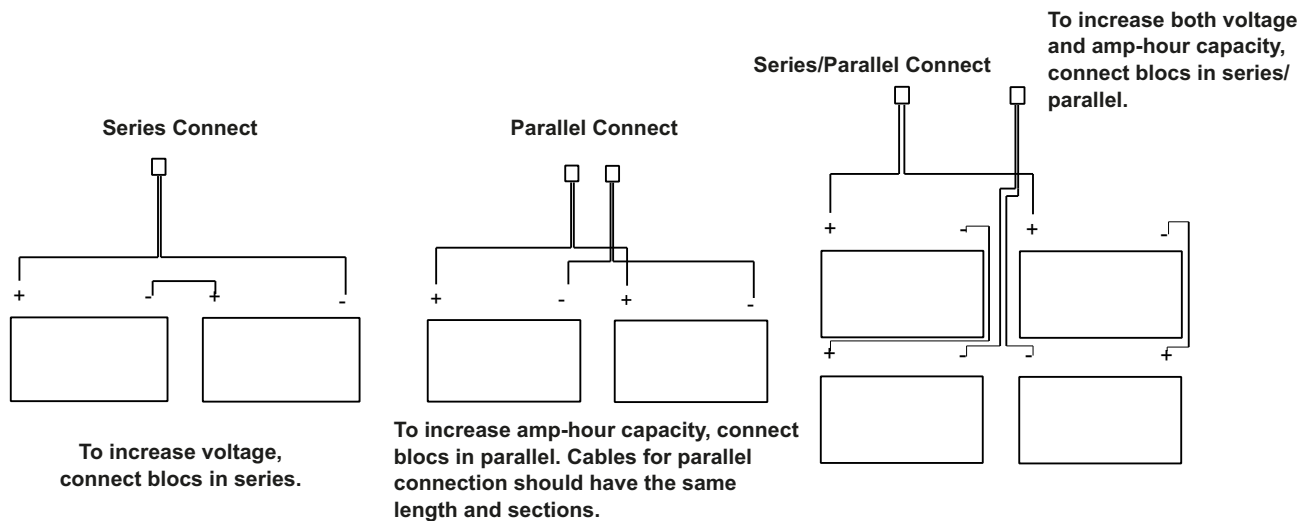

Note: Connecting blocs in a series does not increase the capacity of the blocs; it simply increases the overall voltage to meet your system requirements. If additional capacity is needed, you can connect multiple blocs in parallel as long as your equipment's voltage requirements are met. See diagrams.

Determine the optimum terminal and connection method

Finally, see which types of terminals are available for the bloc you have selected and choose the best for your needs based on the type of cable connections you intend to use. When connecting your blocs, take care to use a proper cable size to avoid overheating your connections.

Note: For information regarding correct wire sizes you can refer to the National Electric Code or contact an EnerSys® representative.



ENERSYS EMEA
EH Europe GmbH
Baarerstrasse 18
6300 Zug, Switzerland
Tel.: +41 44 215 74 10
Fax: +41 44 215 74 11

ENERSYS LTD
Oak Court, Clifton Business Park
Wynne Avenue, Swinton Manchester M27 8FF
United Kingdom
Tel.: +44 161 794 4611
Fax: +44 161 727 3809

www.enersys.com